

**GLASSWARE**  
**AUDIO DESIGN**

**CCDA**

**Constant-Current-Draw Amplifier**

Stereo Octal PCB

## **USER GUIDE**

Introduction  
Overview  
Schematics  
Recommended Configurations  
Tube Lists  
Assembly Instructions

NOV 9 2009

**⬅ Warning! ➡**

This PCB contains a high-voltage power supply; thus, a real and lethal shock hazard exists. Once the power transformer is attached, be cautious at all times. In fact, always assume that the high voltage capacitors will have retained their charge even after the power supply has been disconnected or shut down. If you are not an experienced electrical practitioner, before applying the AC voltage have someone who is experienced review your work. There are too few tube-loving solder slingers left; we cannot afford to lose any more.

### **CCDA Octal PCB Overview**

Thank you for your purchase of the GlassWare CCDA octal stereo PCB. This FR-4 PCB is extra thick, 0.094 inches (inserting and pulling tubes from their sockets won't bend or break this board), double-sided, with plated-through heavy 2oz copper traces. In addition, the PCB is lovingly and expensively made in the USA. The boards are 6 by 6 inches, with five mounting holes, which helps to prevent excessive PCB bending while inserting and pulling tubes from their sockets.

Each PCB holds two CCDA (constant-current-draw amplifier) line-stage amplifiers; thus, one board is all that is needed for stereo unbalanced use (or one board for one channel of balanced line-stage amplification). By including the necessary components for the heater and high voltage B+ power supplies on the PCB, the CCDA board makes building a standard-setting line stage amplifier a breeze. This assembled board with a chassis, volume control, selector switch, power transformer, and a fistful of RCA jacks is all that is needed.

### **PCB Features**

**B+ and Heater Power Supplies** On the CCDA board, two power supplies reside, one for the high-voltage B+ for the tubes and a low-voltage power supply for the heaters. The high-voltage power supply uses an RC filter to smooth away ripple, while the low-voltage power supply uses a voltage regulator to provide a stable and noise-free voltage output. The heater regulator is adjustable and can be set to 6V or 12V. The power supplies require an external power transformer(s) with two secondary windings (120Vac to 260Vac and 12Vac to 12.6Vac).

**Redundant Solder Pads** This board holds two sets of differently-spaced solder pads for each critical resistor, so that radial and axial resistors can easily be used (radial bulk-foil resistors and axial film resistors, for example). In addition, most capacitor locations find many redundant solder pads, so wildly differing-sized coupling capacitors can be placed neatly on the board, without excessively bending their leads.

**Power-Supply-Decoupling Capacitors** The CCDA PCB provides space for two sets of capacitors to decouple both CCDA gain stages from the B+ connection and each other. This arrangement allows a large-valued electrolytic capacitor and small-valued film capacitor to be used in parallel, while a series voltage-dropping resistor completes the RC filter. (As an option, in place of the series resistor, an off-board choke can be used for each channel.)

## Introduction to the CCDA Circuit

The Constant-Current-Draw Amplifier is a compound circuit that holds a grounded-cathode amplifier directly cascaded into a cathode follower. So what; what's so special about this obvious pairing? Its special status lies in the details. Each triode sees the same cathode to plate voltage and the same load resistance and same idle current draw. Each sees the same signal voltage swings. Both grounded-cathode amplifier and the cathode follower are in voltage phase, but not current phase. For example, as the grounded-cathode amplifier sees a positive going input signal, its plate current increases, which increases the voltage developed across the plate resistor, which in turn swings the plate voltage down. This downward voltage swing is then cascaded into the grid of the cathode follower, which decreases the plate current to the same degree that the previous stage's current increased. This results in the constant current draw feature of this topology (a highly desirable feature, as the signal amplification will not alter the amount of current being sourced from the power supply and consequently not perturb the power supply, thus greatly simplifying the design consideration of the power supply).

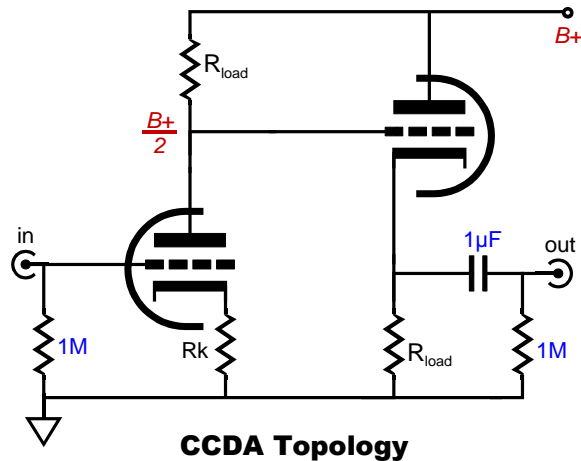

A line stage is needed either to boost a weak signal voltage sufficient to drive a power amplifier to full output, or to deliver current sufficient to drive a high capacitance load (such as long stretches of interconnect). Just how much gain is needed for a line amplifier? Let's begin the answer with the observation that most line amplifiers have too much gain. While this extra gain impresses the audio neophyte who marvels at the power implicit in the distorted thunder that a mere one quarter twist of the volume knob provokes, it ultimately only subtracts from the useful range of turn on the volume and usually only worsens the signal-to-noise ratio of the line stage. If 20 to 30 dB of gain is too much, how much then is best? The answer will depend on each system. A safe guess, however, would be 10 to 20 dB of gain, which translates into 3 to 10 times the input signal. Calculating the gain from a CCDA amplifier is easy, when the cathode resistor is left un-bypassed, as the gain roughly equals half the mu of the input triode used. For example, a 6SN7 presents a mu of 20, so the gain will equal 10 (+20dB). The gain from a simple grounded-cathode amplifier, with a bypassed cathode resistor, is a bit more complicate:

$$\text{Gain} = \mu R_a / (r_p + R_a).$$

For example, given a 6SN7 loaded by a 20k plate resistor and whose cathode resistor is capacitor bypassed, the gain will roughly equal 14 (+23dB).

**CCDA PCB** Obviously, on this PCB many more components have been added to the basic CCDA circuit. R3 and R5 are grid-stopper resistors and are essential, particularly for the cathode follower output stage. The added diode is also essential, as it protects the second triode at startup, when the cathodes are cold and the cathode follower's cathode sits at 0V and its grid sees the full B+ voltage—never a good idea, as the cathode can see portions of its surface ripped away by the huge voltage differential. C2 and C3 are cathode-bypass capacitors, which if used will both increase the grounded-cathode amplifier's signal gain and improve its PSRR figure, but at the cost of increased distortion. C1 is the output coupling capacitor and C15 its small bypass capacitor. C4 and C5 are power supply filtering capacitors which, with resistor R9, define a simple RC filter. R7 (the extra cathode resistor) is optional, although highly recommended, as it buffers the cathode follower's output from heavily-capacitive loads and it increases the cathode follower's linearity, but at the cost of increased output impedance.

**Super low output impedance is essential, isn't it?** In order to avoid insertion loss and frequency droop, a low output impedance is absolutely necessary isn't it? Well, it depends. Consider that cheap OpAmps such as the LM741 have amazingly low output impedances because of the high feedback ratios they run; yet they can't drive low impedance loads because they are output current limited. Yet a discrete transistor line amplifier—with higher output impedance (because of less feedback) and a greater output current capability—may drive the same low impedance load extremely well. So which was the more crucial factor: low output impedance or high current output?

Of course, if the power amplifier presents an extremely-low load impedance, a low output impedance will be needed just to preserve signal level, but not necessarily to preserve bandwidth, as any cable capacitance would effectively be countervailed by the load's own low impedance. No, the real threat to bandwidth comes from high impedance loads, which are bogged down by the high capacitance (because of long interconnects and the power amplifier's own input capacitance); and when this capacitance cannot be charged and discharged quickly enough, poor bandwidth results. The key words in the previous sentence were "charged" and "discharged." Charging a capacitor quickly requires current. The quicker the charging, the greater the current flow. The formula is a simple one: Current = Slew Rate x Capacitance or

$$I = SR \times C,$$

where slew rate refers to the amount of voltage that must be developed within a certain amount of time. Therefore, in order to guarantee wide bandwidth, the line stage must be capable of delivering a fairly high current at its output.

**Isn't phase inversion bad?** The CCDA inverts the signal polarity and phase inversion to be avoided at all costs...right? No, unless you can't reverse the positive/negative connections of the speaker cable to the power amplifier. Line stage phase inversion just needs a screwdriver to fix. If the line amplifier inverts the phase and the power amplifier doesn't, then invert the speaker's phase. If the line amplifier inverts the phase and the power amplifier also inverts, then don't invert the speaker's phase.

## GlassWare Audio Design

Unlike the Aikido, which delivers a perfect platform for tube rolling, as vastly different tubes can be swapped in and out of the board (6BL7 or 6SL7) without having to change the resistor values, the CCDA requires more care in selecting resistor values. For example, a 6SN7-based CCDA line-stage amplifier that used 20k plate and 430-ohm cathode resistors could never accept a 6SL7, 6H30Pi, or 6SN7, as the resulting plate voltage would not center at  $B^+/2$ , which the CCDA requires. The problem is, assuming that even if we stick to just one tube type, the daunting array of different possible  $B^+$  voltages. For example, a 6SN7-based line-stage amplifier might run a  $B^+$  voltage of only 140Vdc or as much as 300Vdc. Assuming an idle current of 7.5mA per triode, a huge array of plate and cathode resistors would be needed. Moreover, the plate resistor cannot be the little 1/2W devices that the Aikido freely uses, but big 2W (or 3W) power resistors, which are hard to find and expensive. The solution the problem of too many resistor combinations is to let the idle current move, but lock the plate and cathode resistor values. A triode with a cathode and plate resistors acts like a resistor, not a perfect resistor, but a fairly good one.

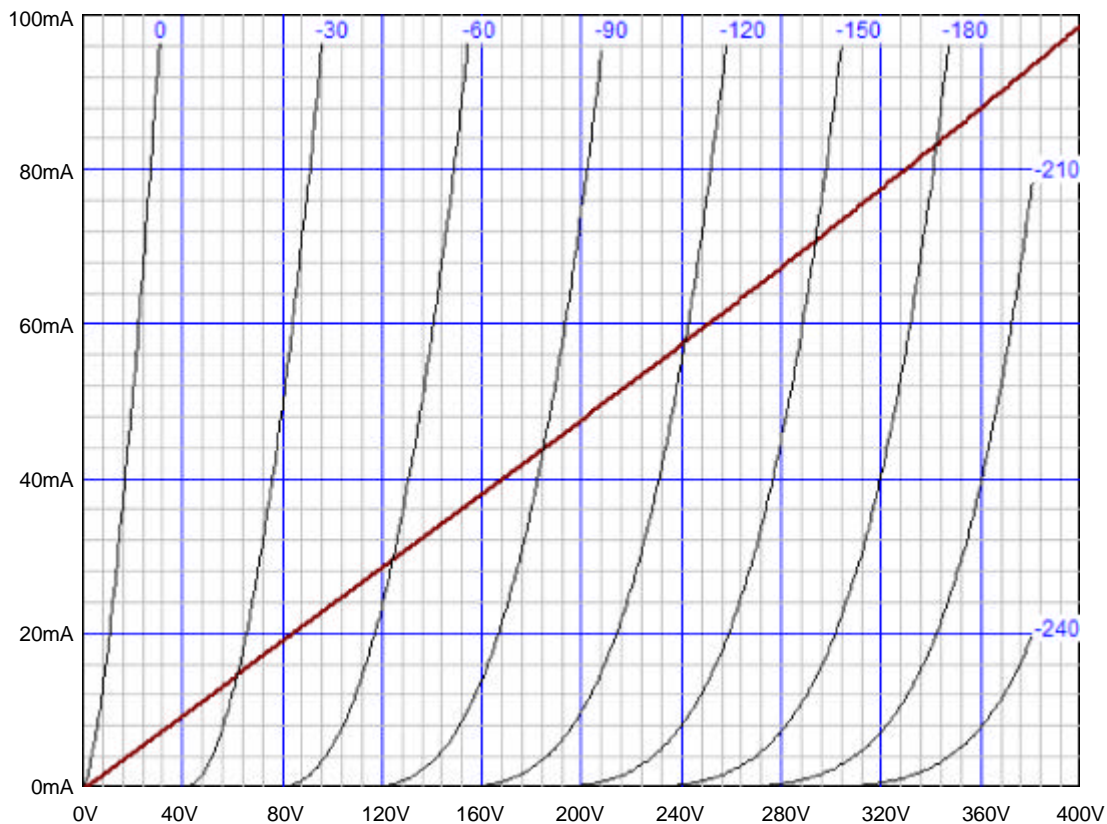

As the graph above reveals, a 6AS7 triode with a 1300-ohm cathode resistor behaves much like a 4k resistor. (By the way, note the much improved linearity over the plate curve lines, albeit at the cost of greatly increased plate resistance and reduced transconductance. Adding a plate resistor also makes the triode behave more like a good resistor.) The formula for the effective resistance (with  $R_k$ ) is:

$$R = r_p + R_a + (\mu + 1)R_k.$$

The upshot is that if we chose plate and cathode resistor values to work at the middle of possible  $B^+$  voltages, these same  $R_a$  &  $R_k$  resistor pairs will still split the  $B^+$  voltage across a wide range of  $B^+$  voltages.

**What does the diode do in this circuit?** This diode does not do anything during the normal operation of the circuit. It can't, as the diode is so placed that the cathode would have to be at some lower voltage than is the grid, which under normal operation does not happen. The tube (being a depletion mode device) conducts current in spite of the grid being negative relative to the cathode, which is the basis for cathode biasing, or as it is sometimes called "auto biasing." If the grid were to become positive relative to the cathode, however, the diode would conduct and the greatest voltage difference between the grid and cathode would equal the voltage drop across the diode, which is usually between 0.3 to 1.2 volts. A situation that could happen if the grid were driven with an excessively large input voltage or if the B+ voltage were established and the tube remained too cold to emit electrons. The latter situation is what usually happens every the circuit is turned power up.

**Alternate Cathode Resistor Connection** For the advanced practitioner, the CCDA All-in-One PCB accepts two ways of bypassing the grounded-cathode amplifier's cathode resistor. The first is to use jumper J5 and capacitors C2 & C3. The second approach is to use jumper J4 and forgo the bypass capacitors. The first configuration requires halving the cathode resistor's nominal value, as twice the current will flow through the resistor. The resistor is effectively bypassed, however, as anti-phase AC current flows from the cathode follower side of the circuit into the cathode resistor, effectively establishing a DC current flow and constant voltage drop across the resistor. (In reality, a small amount of AC current signal will superimpose a small AC signal across the resistor.) Just as we can wear a belt with suspenders, the bypass capacitors can be added to this configuration. But do first try it without the capacitors.

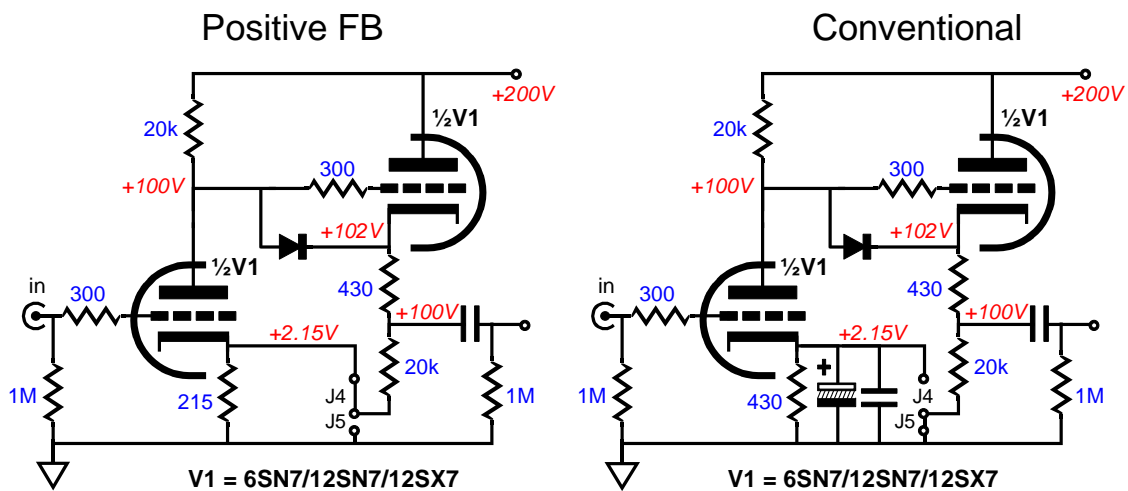

No doubt many applications do require all the gain and the PSRR improvements possible, such as an MC cartridge pre-preamp or a microphone preamp; but for line-stage amplifier use, the bigger problem is usually too much gain, not too little. For example, a 12SX7-based CCDA line-stage amplifier, with an unbypassed cathode resistor, will deliver a voltage gain of about 10, or 20dB, which is plenty. And the 6SL7 offers a very high  $\mu$  of 70 and, thus, will deliver a gain 35, or +10dB more than the 12SX7 (or 6SN7), with an unbypassed cathode resistor. Be sure to try the CCDA with configuration on the right and without bypass capacitors first.

## Cathode Resistor Values

The cathode resistor and plate voltage set the idle current for the triode: the larger the value of the resistor, less current; the higher the plate voltage, more current. In general, high- $\mu$  triodes require high-value cathode resistors (1-2K) and low- $\mu$  triodes require low-valued cathode resistors (100-1k). The formula for setting the  $I_q$  is both simple and fairly accurate:

$$I_q = B+ / (R_a + r_p + [\mu + 1]R_k)$$

So, for example, a 6SN7 in a CCDA with a B+ voltage of +300V and 860 cathode resistors will draw  $300 / (30k + 6.5k + [2 + 1]860)$  amperes of current, or about 5.5mA. But in the CCDA, the input triode's cathode resistor must do more than just set the idle current: it must also set the plate voltage to half that of the B+ voltage. So we must work backwards from the B+ voltage and the plate resistor's value to zero in on the correct cathode resistor value. For example, assuming a 6SN7 triode and final B+ voltage of 250Vdc and a plate resistor value of 20k, we know that half the B+ is equal to 125Vdc, which divided by the 20k plate resistor equals an idle current equal to 6.25mA.

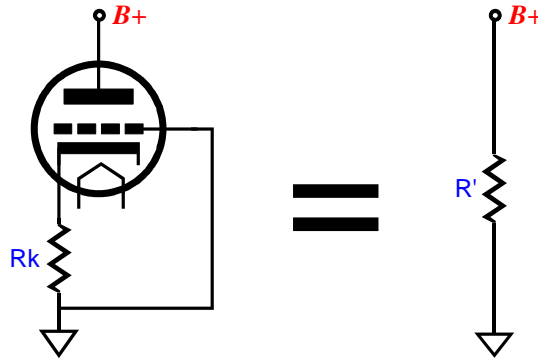

Now, we must find the cathode resistor value that will ensure the halving of the B+ voltage. Fortunately, a simple formula gets us close:

$$R_k = (R_a - r_p) / (\mu + 1)$$

Thus, in this example, using the tube manual's specifications of a  $\mu$  of 20 and an  $r_p$  of 6.5k,  $R_k$  should equal 643 ohms. In fact this resistor will result in too little current being drawn, resulting in a plate voltage 15V too high; and the empirically derived value is closer to 430 ohms. Refer to chart below for many more illustrations.

Rk for Plate Resistor Values

| TUBE          | 1.5K | 10K | 20K  | 30K | 75K | 150K |
|---------------|------|-----|------|-----|-----|------|
| <b>6BL7</b>   | NA   | 360 | 960  | NA  | NA  | NA   |
| <b>6BX7</b>   | NA   | 760 | 1760 | NA  | NA  | NA   |
| <b>6H30Pi</b> | NA   | 530 | 1200 | NA  | NA  | NA   |
| <b>6SL7</b>   | NA   | NA  | NA   | NA  | 845 | 1.5K |
| <b>6SN7</b>   | NA   | NA  | 430  | 845 | NA  | NA   |
| <b>12SX7</b>  | NA   | NA  | 430  | 760 | NA  | NA   |
| <b>6082</b>   | 360  | NA  | NA   | NA  | NA  | NA   |

## B-Plus Power Supply

The high voltage B-plus power supply resides on the CCDA PCB. It contains a full-wave bridge rectifier circuit and reservoir capacitor, which is then followed by an RC-smoothing filter. The high voltage power transformer is external to the PCB and can be mounted in, or outside, the chassis that houses the PCB.

The optimal B-plus voltage depends on the tubes used. For example, 12SX7s can be used with a low 48V power supply, while 6H30Pi tubes work better with a 100V to 240V B-plus voltage; 6SN7s and 12SN7s, 200V to 300V. The sky is not the limit here, as the power supply capacitors and the heater-to-cathode voltage set an upward limit of about 350V for the power supply voltage after the rectifiers and about 300V at the tubes after the RC filter.

Resistors R9 are the resistors in the RC power supply filters with capacitors C4 & C5. Resistor heat equals  $P \times R$  (and  $V^2/R$ ); for example, 20mA and 5k will dissipate 2W. See page 12 and the back inside cover for more information. Several goals that work against each other: we want the largest voltage-dropping resistor value possible, as it reduces the ripple CCDA's power supply connection; and we want the smallest value for R9, as this resistor limits the maximum idle current that can flow through the CCDA stage; and we want the lowest raw B-plus voltage possible, as it will allow a larger-valued reservoir capacitor and limit the heater-to-cathode voltage; and we want the highest plate voltage possible for the tubes, as it makes for better sound. We cannot have it all. Choices must be made and consequences must be accepted.

An analogy can be made between cars and a tube line-stage amplifier. A race car runs high revs and high horsepower and it is obscenely expensive, noisy, unreliable, and glorious to behold. A family's commuter car is cheap, quiet, reliable, and boring. Running high voltage and high current will make for a short tube life and a wonderful sound. Running low voltage and low current will greatly extend tube life and save money on part cost. For example, a typical 250V capacitor is much more volumetrically efficient and cheaper than a 400V capacitor. Thus, running a lower B-plus voltage allows us to increase greatly the total capacitance in the power supply, at a lower cost.

### Typical Part Values

() Parentheses denote recommended values

- C4 = 0.1 $\mu$ F to 1 $\mu$ F\* (0.33 $\mu$ F 630V)
- C5 = 47 $\mu$ F to 470 $\mu$ F\* (150 $\mu$ F 400V)
- C6 = 33 $\mu$ F to 100 $\mu$ F\* (33 $\mu$ F 450V)
- C13 = 0.01 $\mu$ F to 0.47 $\mu$ F  $\geq$  100V

\*Voltage depends on transformer used; all must exceed the B+ voltage.

D1-4 = 1N4007, UF4007, HEXFRED (HER108)

- R9 = 100 to 10k
- R10-13 = 10 1W
- R15 = 300k 1W
- R14 = 50k to 100k 1W

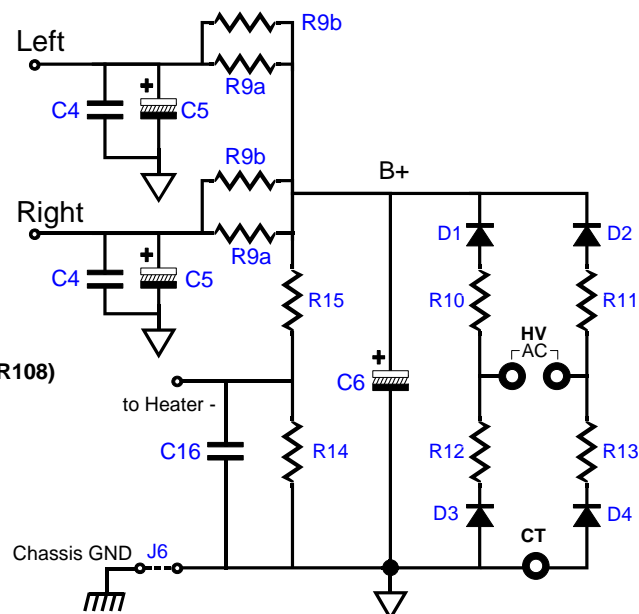

## Power Transformer(s)

The CCDA PCB requires a power transformer(s) to energize its two power supplies. The heater power supply power transformer must offer at least 1.8 times more current than the heaters will draw. For example, two 6SN7s will draw 0.6A @12.6v, so the heater power transformer must be able to sustain an AC 1.08A current draw. In addition, with sine waves, the AC voltage equals the peak voltage divided by the square root of 2, i.e. 1.414. For example, a 10Vac sine wave peaks at 14.14V; a 6.3Vac, 8.9V. In other words, a sine wave that peaks at 14.14V will produce the same amount of heat in a resistance as a 10Vdc voltage source would produce across the same resistance; thus, we label the 14.14Vpk sine wave as being 10Vac. In order to get the 16Vdc raw DC voltage that a 12.6V heater voltage regulator requires an input voltage equal to remainder of 16V minus the rectifier loss (about 2V) divided by 1.414, which is roughly 12.6Vac.

The high voltage power transformer must also follow the same rules. Thus, to achieve 300V of raw DC voltage, the transformer primary must deliver  $(300V + 2V) / 1.414$ , or about 214Vac. And if 50mA is required, the power transformer must be rated for  $50mA \times 1.8$  (in a full-wave bridge rectifier circuit), or 90mA. Thus, such a transformer VA rating would be rated about 20VA, as  $0.9 \times 214 = 19.71$ .

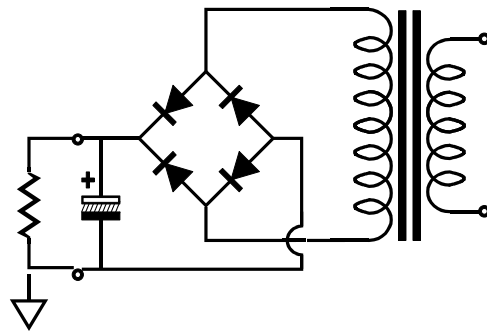

$$I_{out} = I_{ac} / 1.8$$

$$V_{dc} = (V_{ac} \times 1.4) - 2V_{diode}$$

**Full-Wave Bridge** This is the most popular power supply configuration. The entire primary winding is used and four rectifiers are required. This configuration is seldom used with tube rectifiers, as the rectifier cathodes cannot be heated by just a single heater winding. The two solid-state diode voltage-drops count for little in a high-voltage power supply, but are a big liability in low-voltage power supplies.

A center-tapped primary can be used as well; just leave D3, D4, R12, and R13 off the board, then attach the center-tap to D3 or D4's bottom eyelet, where its label appears.

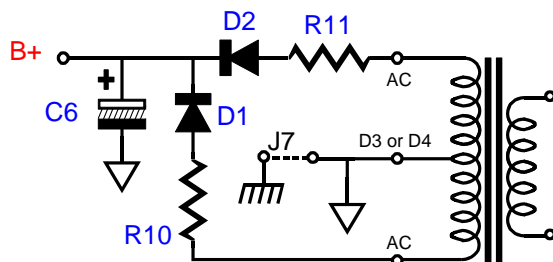

Center-Tapped Transformer

$$I_{out} = I_{ac} / 1.27$$

$$V_{dc} = V_{ac}^* / 1.43 - V_{diode}$$

\*entire primary

## Heater Issues

The CCDA PCB holds the heater raw power supply and voltage regulator. The regulator uses the LD1085 low-dropout adjustable voltage regulator. The regulator can be set to an output voltage between 6V to 25V, but the assumption is that a 12Vdc output voltage will be used for the heaters, so that 6.3V heater tubes (like the 6BX7 and 6SN7) or 12.6V tubes (like the 12SL7 or 12SN) can be used. One heater-voltage type tube must be used exclusively. In other words, do not use a 12SX7 and a 6SN7 at the same time.

Although the preferred power supply voltage is 12V, a 6Vdc (or 6.3Vdc) heater power supply can be used with the PCB, as long as all the tubes used have 6.3V heaters (or a 5V or 8V or 18V power supply can be used, if all the tubes share the same 5V or 8V or 18V heater voltage). Note: Perfectly good tubes with uncommon heater voltages can often be found at swap meets, eBay, and surplus stores for a few dollars each. Think outside 6.3V box. To place the two tube heater elements in series, use jumper J2; in parallel, J1 & J3.

**AC Heaters** An AC heater power supply (6.3V or 12.6V) can be used, if the heater rectifiers, power supply capacitors, and regulator are all left off the board. This is not in the least recommended, as the high-current AC voltage will introduce hum and compromise the bass reproduction.

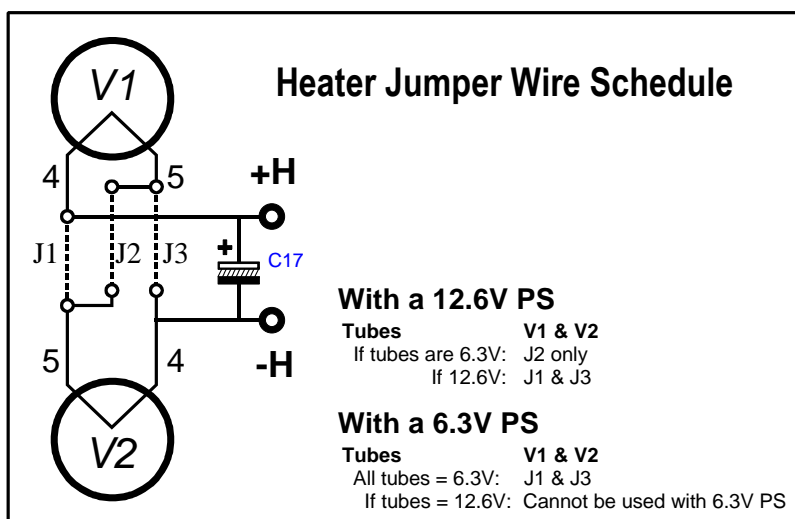
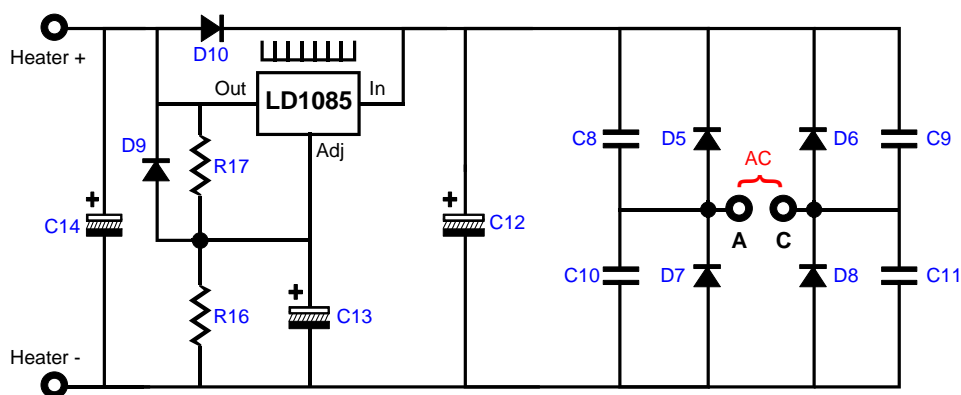

## GlassWare Audio Design

Since one triode's cathode sits close to ground potential and the other close to half the B+ voltage, the heater-to-cathode voltage experienced differs between triodes. The safest path is to reference the heater power supply to a voltage equal to one fourth the B+ voltage that appears after resistor R9; for example, 75V, when using a final 300V B+ voltage. The 1/4 B+ voltage ensures that both top and bottom triodes see the same magnitude of heater-to-cathode voltage. The easiest way to set this voltage relationship up is the following circuit:

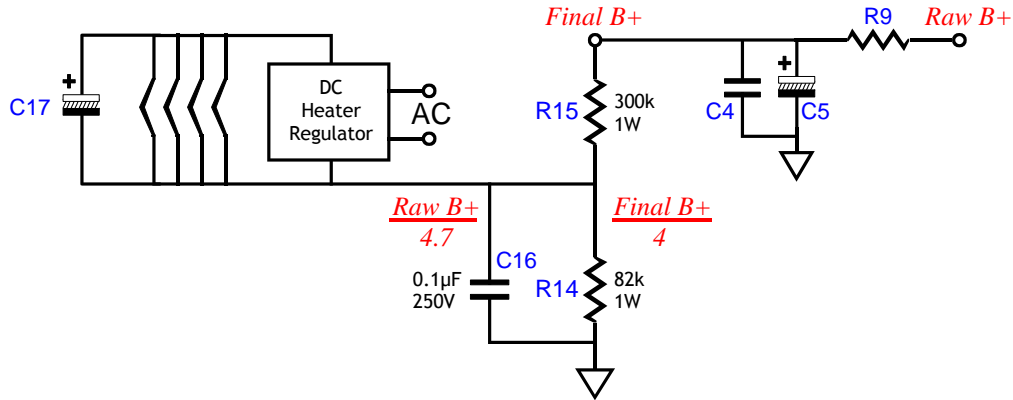

The target reference voltage for the heater's power supply is one quarter of the B-plus voltage that the CCDAs tubes see, not the initial raw B-plus voltage at C6. This means that resistors R15 and R14 values must be experimentally selected. Alternatively, you might experiment with floating the heater power supply, by "grounding" the heater power supply via only a 0.1µF film or ceramic capacitor, leaving resistors R15 and R14 off the board. The capacitor will charge up through the leakage current between heater and cathodes. Not only is this method cheap, it is often quite effective in reducing hum with certain tubes.

### Typical Part Values

| Heater Voltage = | 6V   | 6.3V | 8V   | 12V   | 12.6V |
|------------------|--|------|------|-------|-------|
| R16 =            | 470  | 499  | 670  | 1.07k | 1.13k |
| R17 =            | 124  | same | same | same  | same  |
| D5 - D8 =        | MUR410G  | "    | "    | "     | "     |
| D1, 2, 9, 10 =   | 1N4007   | "    | "    | "     | "     |
| C8 - C9 =        | 0.01µF - 50V   | "    | "    | "     | "     |
| C12 =            | 10kµF - 16V  | "    | "    | "     | "     |
| C13, C14 =       | 1kµF - 16V   | "    | "    | "     | "     |
| C17 =            | 3900µF - 16v   | "    | "    | "     | "     |
| Regulator =      | LD1085, LM317, LM350, LT1085                                     |      |      |       |       |
| Vac Input =      | 7-8Vac @ 5A for 6.3Vdc<br>12-12.6Vac @ 2.5A for 12Vdc or 12.6Vdc |      |      |       |       |

Resistors R16 and R17 set the heater voltage regulator's output voltage. The formula is

$$V_0 = 1.25(1 + R_{16} / R_{17})$$

For example, using a 125-ohm resistor for R17 and a 1.07k resistor in R16 position, the output will climb to 12Vdc. See the values table above.

## Grounding

The CCDA PCB holds a star ground at its center. Ideally, this will be the only central ground in the line-stage amplifier. Ground loops, however, are extremely easy to introduce. For example, if the RCA jacks are not isolated from the chassis, then the twisted pair of wires that connect the PCB to the jacks will each define a ground loop (as will jumper J6, which bridges the PCB's ground to the chassis). The solution is either to isolate the jacks or use only a single hot wire from jack to PCB (the wire can be shielded, as long as the shield only attaches at one end). Thus, the best plan is to plan. Before assembling the line-stage amplifier, stop and decide how the grounding is going to be laid out, then solder.

Three different schools of thought hold for grounding a piece of audio gear. The Old-School approach is to treat the chassis as the ground; period. Every ground connection is made at the closest screw and nut. This method is the easiest to follow and it produces the worst sonic results. Steel and aluminum are poor conductors.

The Semi-Star ground method uses several ground "stars" that are often called spurs, which then terminate in a single star ground point, often a screw on the chassis. This system can work beautifully, if carefully executed. Unfortunately, often too much is included in each spur connection. For example, all the input and output RCA jacks share ground connection to a long run of bare wire, which more closely resembles a snake than a spur ground. In other words, the spurs should not be defined just physical proximity, but signal transference. Great care must be exercised not to double ground any spur point. For example, the volume control potentiometer can create a ground loop problem, if both of its ground tabs are soldered together at the potentiometer and twisted pairs, of hot and cold wires, arrive at and leave the potentiometer, as the two cold wires attaching to the PCB will define a ground loop.

The Absolute-Star grounding scheme uses a lot of wire and is the most time consuming to execute, but it does yield the best sonic rewards. Here each input signal source and each output lead gets its own ground wire that attaches, ultimately, at one star ground point; each RCA jack is isolated from the chassis. The CCDA PCB was designed to work with this approach, although it can be used with any approach.

**House Ground** The third prong on the wall outlet attaches to the house's ground, usually the cold water pipe. The line-stage amplifier can also attach to this ground connection, which is certainly the safest approach, as it provides a discharge path should the B+ short to the chassis. Unfortunately, this setup often produces a hum problem. Some simply float the ground, others use several solid-state rectifiers in parallel to attach the chassis ground to the house ground (**NOT NEUTRAL**) via the third prong, and others still use a 10-ohm resistor shunted by a small capacitor, say 0.001 $\mu$ F to 0.1 $\mu$ F/250V.

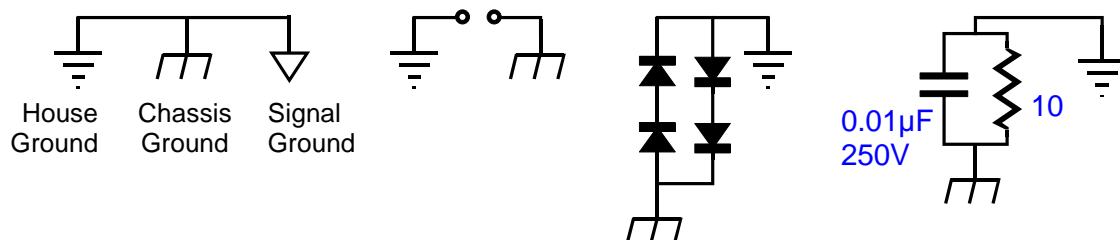

A good test procedure is to detach all the signal inputs and all the output connection from the line-stage amplifier. Then measure the AC voltage between the line-stage amplifier's chassis and the house's ground. If it reads more than a few volts, try reversing the line-stage amplifier's plug as it plugs into the wall socket. Use whichever orientation that results in the lowest AC voltage reading. Then measure the chassis ground to the first signal source's ground (while the signal source is turned on). Once again flip the signal source's plug until the lowest AC voltage setting is found. Then do the rest with the rest of the system. The results can prove far more satisfying than what would be yielded by buying thousand-dollar cables.

**Chassis Ground** Jumper J6 connects the PCB's ground to the chassis through the top leftmost mounting hole. If you wish to float the chassis or capacitor couple the chassis to ground, then either leave jumper J6 out or replace it with a small-valued capacitor (0.01 to 0.1 $\mu$ F). Warning: if rubber O-rings are used with PCB standoffs, then the ground connection to the chassis is not likely to be made; tubes, use metal washer in place of top O-ring.

**CATV Ground** Attaching a line-stage amplifier to TV or VCR can cause huge hum problems, as the "ground" used by the connection CATV connection may introduce hum. Isolation transformers work supremely well in this application. In fact, an isolation transformer can be used on all the input signals only (one transformer per channel is required, if it is located after, rather than before the selector switch.) Look on the Web for more complicated solutions to the CATV hum problem.

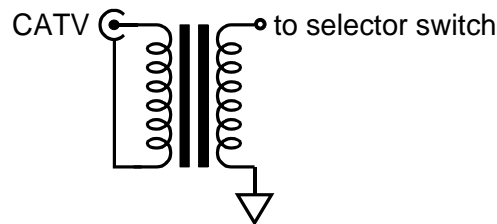

### Power-Supply RC Filter

Resistors R9a and R9b are in parallel. The CCDA kit supplies six pairs of 3W resistors for R9 use: 1.6k, 2k, 3k, 3.9k, 6.8k, and 10k. Each resistor can be used in isolation or in parallel with one other resistor. Twenty-one possible combinations are possible; the resulting parallel resistance is shown in the chart below. The charts on the back-inside cover show the voltage drop across the R9 versus the current flow. Remember each channel gets its own pair of R9 resistors. For example, a CCDA amplifier might run each triode with 5mA of idle current, which is a total of 10mA per each channel. So by looking up the 10mA column, we can see the resulting voltage drops. Thus, one 3k resistor will drop 30V, so a 280Vdc raw DC power supply will deliver 250Vdc to the tubes. An "\*" denotes excessive current or voltage, so that combination cannot be used without risking damaging the at least one of the resistors.

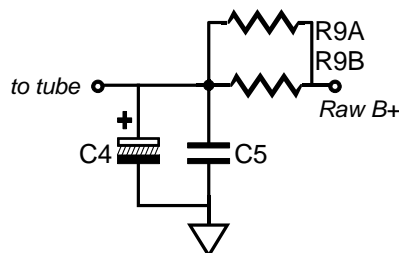

## Configuring a CCDA Line Amplifier

The CCDA topology makes a good line amplifier, as it offers low distortion and low output impedance. The following design examples are by no means exhaustive, as many more equally “correct” configurations are possible. For example, a beefy 6BX7-based CCDA line-stage amplifier that ran the triodes under high current might prove the best solution for those planning driving long high-capacitance cables.

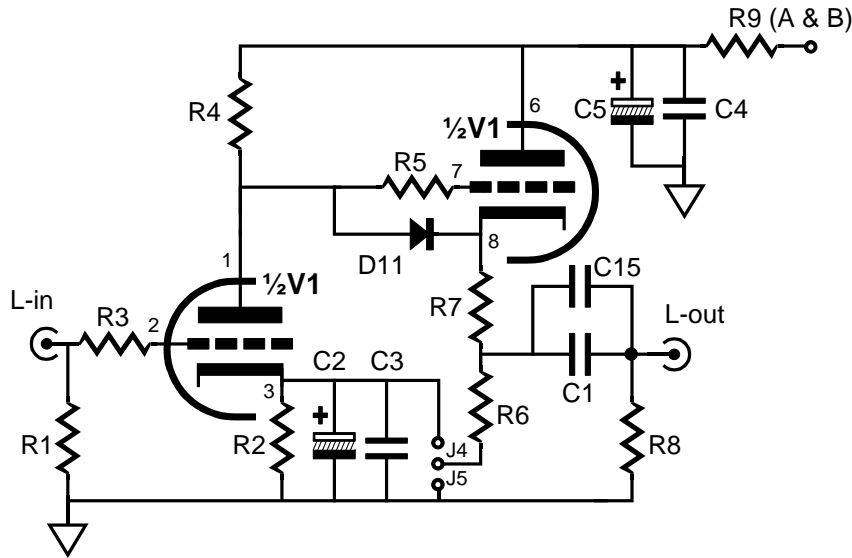

### Typical Part Values ( ) Parentheses denote recommended values

| Tube =                             | 6SN7                    | 6H30pi             | 12SX7              | 6SL7               |
|------------------------------------|-------------------------|--------------------|--------------------|--------------------|
| <b>B+ Voltage =</b>                | 150V - 300V (250V)      | 100V - 240V (200V) | 200V - 300V (250V) | 200V - 300V (275V) |
| <b>Heater Voltage =</b>            | 6.3V or 12.6V           | 12.6V              | 12.6V              | 6.3V               |
| <b>R1,8 =</b>                      | 100k - 1M (1M)          | Same               | Same               | Same               |
| <b>R2,5 =</b>                      | 430                     | 530                | 560                | 1.5k               |
| <b>R3,7 =</b>                      | 100 - 1k (300)          | Same               | Same               | Same               |
| <b>R4,6 =</b>                      | 20k                     | 10k                | 20k                | 150k               |
| <i>With R2 unbypassed &amp; J5</i> |                         |                    |                    |                    |
| <b>Gain =</b>                      | 10                      | 7                  | 10                 | 35                 |
| <b>Gain dB =</b>                   | +20dB                   | +17dB              | +20dB              | +30dB              |
| <i>With R2 bypassed or J4</i>      |                         |                    |                    |                    |
| <b>Gain =</b>                      | 15                      | 12.5               | 15                 | 50                 |
| <b>Gain dB =</b>                   | +23dB                   | +22dB              | +23dB              | +34dB              |
| <i>With R7</i>                     |                         |                    |                    |                    |
| <b>Zo =</b>                        | 700 ohm                 | 600 ohm            | 700 ohm            | 2.6k               |
| <i>With replaced by jumper</i>     |                         |                    |                    |                    |
| <b>Zo =</b>                        | 300 ohm                 | 110 ohm            | 300 ohm            | 590 ohm            |
| <b>C1 =</b>                        | 0.1 - 10µF* Film or PIO | Same               | Same               | Same               |
| <b>C2 =</b>                        | 1kµF/16V Optional       | "                  | "                  | "                  |
| <b>C3 =</b>                        | 0.01 - 0.1µF Optional   | "                  | "                  | "                  |
| <b>C4 =</b>                        | 0.1 - 1µF* Film or Oil  | "                  | "                  | "                  |
| <b>C5 =</b>                        | 150µF/400V              | "                  | "                  | "                  |
| <b>C15 =</b>                       | 0.1 - 1µF* Film or Oil  | "                  | "                  | "                  |

\*Voltage rating must equal or exceed B+ voltage

## Tube Selection

The CCDA is quite flexible, as a CCDA can be built using many different tubes. For line-stage amplifiers, the 6SN7 and 12SX7 are the obvious choices, but other twin-triodes can be used. For example, a 6SL7 input tube will yield a gain close to 35 ( $\mu/2$ ), which would be suitable as the frontend of a single-ended amplifier; a 6SN7 (5692) or 12SX7 input tube will yield a gain near 10, which would be excellent for a line stage amplifier; and the 6BX7 or 6H30Pi would deliver a low output impedance that could drive capacitance-laden cables or even high-impedance headphones. The list of possible tubes is not overly long: 2C50, 6BL7, 6BX7, 6H30Pi, 6SL7, 6SN7, 6SU7, 12SL7, 12SN7, 12SX7, 5691, 5692, 6082, ECC32, ECC33.

The only stipulations are that the two triodes within the envelope be similar and that the tube conforms to the 8BD base pin-out. Do try to think outside the 6 and 12 volt tube box. For example, NOS 6SN7s sell for about \$\$\$, but the same tubes with an 8V or 12V heater can be bought for less than \$10.

## RFI

Radio frequency interference can be a hassle to track down and eliminate. First make sure that the source of the problem actually resides in the line-stage amplifier. For example, if only one signal source suffers from RFI noise, make sure that it is normally RFI free. In other words, attach it to another line-stage amplifier and see if the RFI persists. If it does pass this test, then try soldering small capacitors, say 100pF, from this signal source's RCA jacks to the chassis, as close as possible to the jacks: if it fails, fix the source. Ferrite beads can also help; try using beads on the hot lead as it leaves the RCA jack and then again at the selector switch. Increasing the grid-stopper resistor's (R3) value, say to 1k, can also work wonders (use a carbon-composition or bulk-foil resistor or some other non-inductive resistor type).

## RCA Jack Terminating Resistors

Here's a cheap trick to try: at each input RCA jack, place a 100k to 1M resistor, bridging input hot and jack ground. Why? The resistor provides a path for the AC signal present at the jack, so given a choice between radiating into the chassis or going through the relatively low-impedance resistor, the AC signal chooses the latter path, reducing crosstalk.

## Coupling-Capacitor Values

The bigger in value the coupling capacitor, the lower the -3dB high-pass corner frequency will be. The formula is as follows:

$$\text{Frequency} = 159155/C/R$$

where C is in  $\mu\text{F}$ . For example, with a 1 $\mu\text{F}$  coupling capacitor and a power amplifier with an input impedance of 47k, the corner frequency would be 3.5Hz. The higher the load impedance, the lower the corner frequency. The coupling capacitor voltage rating must at least equal the B+ voltage, for safety's sake. Bypass capacitor (C15) for the coupling capacitors (C1) is optional. Many coupling capacitor benefit from the addition of small bypass capacitors that are one tenth to one hundredth the main coupling capacitor's value. Do not be afraid to experiment. Try bypassing a film coupling capacitor with a PIO (or mica or wet-slug tantalum or Teflon) capacitor.

## Assembly & Testing

**Assembly** Cleanliness is essential. Before soldering, be sure to clean both sides the PCB with 90% to 99% isopropyl alcohol. Do not use dull-looking solder; solder should shine. If it doesn't, first clean away the outer oxidation with some steel wool or a copper scouring pad. If the resistor leads look in the least gray, clean away the oxidation with either steel wool or a wire sniper's sharp edges. Admittedly, with new resistors and a fresh PCB, such metal dulling is rare; but if the parts have sat in your closet for a year or two, then expect a good amount of oxidation to have developed.

First, solder all the small diodes in place, and then solder the resistors, rectifiers, capacitors, and heatsinks. Be consistent in orienting the resistors; keep all the tolerance bands on the resistor's body at the right side as you face the resistor straight on. This will pay dividends later, if you need to locate a soldered a resistor in the wrong location. Because the board is double sided, with traces and pads on each side, it is easier to solder the resistors from their top side. It is often easier to attach the LD1085 (heater regulator) to its heatsink first (using the heatsink hardware kit) and then to solder both the heatsink and regulator to the PCB at once. As the PCB is so overbuilt, it is extremely difficult to remove an incorrectly placed part. Be sure to confirm all the electrolytic capacitor orientations, as a reversed polarized capacitor can easily vent (or even explode) when presented with high-voltage. Confirm twice, solder once.

**Testing** Before testing, visually inspect the PCB for breaks in symmetry between left and right sides. Wear safety eye goggles, which is not as pantywaist a counsel as it sounds, as a venting power-supply capacitor will spray hot caustic chemicals. Make a habit of using only one hand, with the other hand behind your back, while attaching probes or handling high-voltage gear, as a current flow across your chest can result in death. In addition, wear rubber-soled shoes and work in dry environment. Remember, safety first, second, and last.

1. Attach only the heater power supply's transformer winding, leaving the high-voltage transformer leads unattached and electrical tape shrouded, with no tubes in their sockets.
2. Use a variac and slowly bring up the AC voltage, while looking for smoke or part discoloration or bulging.
3. Measure the heater regulator's output voltage without and with a load. If the heater regulator fails to regulate, try either lowering the heater voltage a tad, for example 12V instead of 12.6V, as the 0.6V difference might be enough to bring the regulator back into regulation.
4. Next, power down the heater regulator and attach the high-voltage windings and insert the tubes in their sockets.
5. Attach the transformer to a variac and slowly bring up the AC voltage.
6. Measure the voltage across ground and B-plus pads in the center of the PCB; then measure the voltage across capacitors, C4 & C5. If the two channels differ by more than 10Vdc, try switching tubes from one channel to the other. If the imbalance does not follow the tubes, there is a problem, probably a misplaced part.

Only after you are sure that both heater and B-plus power supplies are working well, should you attach the line-stage amplifier to a power amplifier.

**Top Side PCB Mechanical Layout**

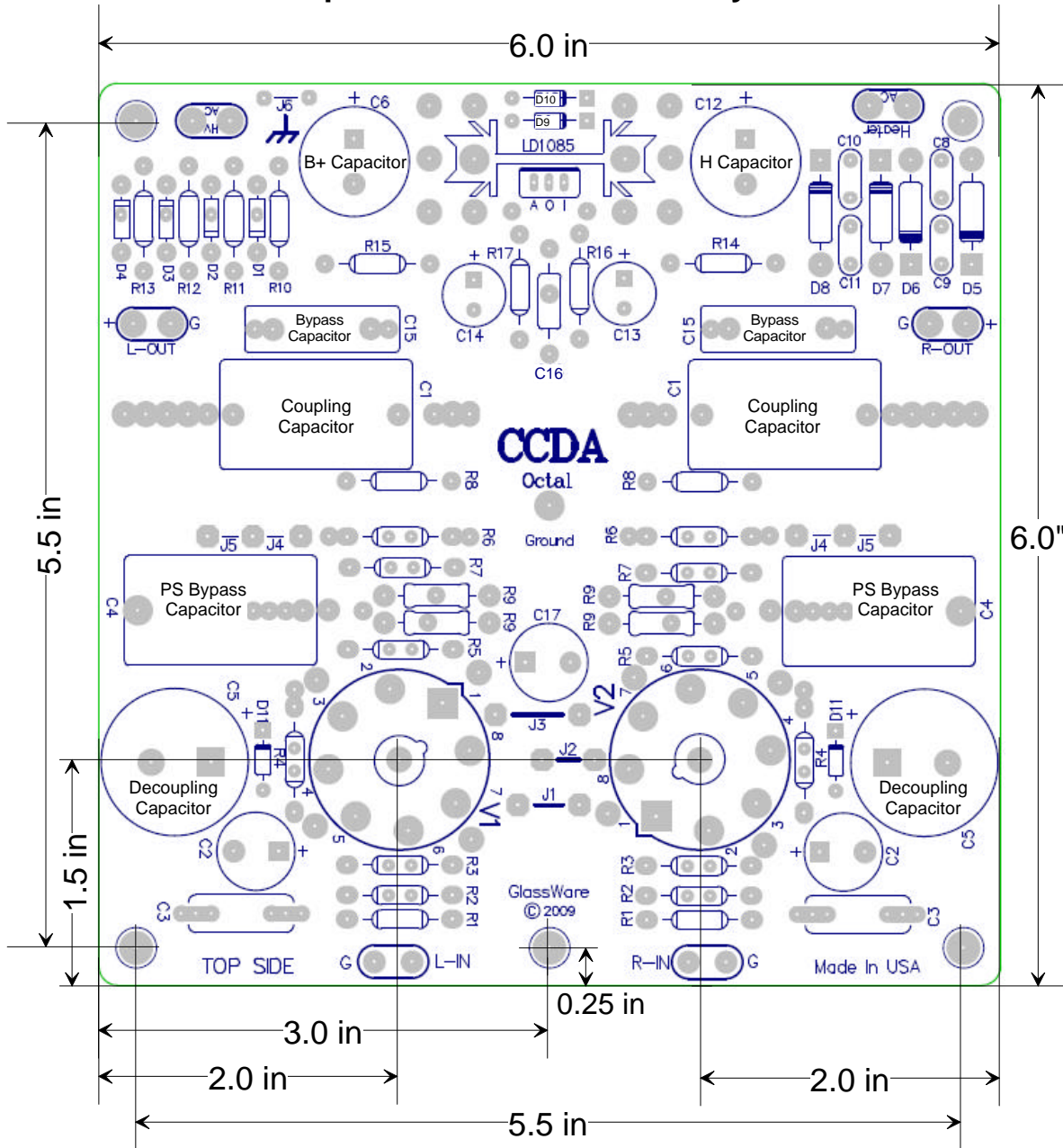

**Let me know what you think**

If you would like to see some new audio PCB or kit or recommend a change to an existing product or if you need help figuring out the heater jumper settings or cathode resistor values, drop me a line by e-mail to the address on the back cover (begin the subject line with either "Aikido" or "tube" or the spam filters are sure to eat your message).

| R     | R9a   | R9b   | I <sub>max</sub> mA | V <sub>max</sub> | W <sub>attage</sub> | F3 150μF | F3 270μF |
|-------|-------|-------|---------------------|------------------|---------------------|----------|----------|
| 889   | 1600  | 2000  | 78                  | 69               | 5.4                 | 1.19     | 0.66     |
| 1043  | 1600  | 3000  | 66                  | 69               | 4.6                 | 1.02     | 0.56     |
| 1135  | 1600  | 3900  | 61                  | 69               | 4.2                 | 0.94     | 0.52     |
| 1295  | 1600  | 6800  | 53                  | 69               | 3.7                 | 0.82     | 0.46     |
| 1379  | 1600  | 10000 | 50                  | 69               | 3.5                 | 0.77     | 0.43     |
| 1600  | 1600  | none  | 43                  | 69               | 3.0                 | 0.66     | 0.37     |
| 1200  | 2000  | 3000  | 64                  | 77               | 4.9                 | 0.88     | 0.49     |
| 1322  | 2000  | 3900  | 58                  | 77               | 4.5                 | 0.80     | 0.45     |
| 1545  | 2000  | 6800  | 50                  | 77               | 3.8                 | 0.69     | 0.38     |
| 1667  | 2000  | 10000 | 46                  | 77               | 3.6                 | 0.64     | 0.35     |
| 2000  | 2000  | none  | 39                  | 77               | 3.0                 | 0.53     | 0.29     |
| 1696  | 3000  | 3900  | 56                  | 95               | 5.3                 | 0.63     | 0.35     |
| 2082  | 3000  | 6800  | 46                  | 95               | 4.3                 | 0.51     | 0.28     |
| 2308  | 3000  | 10000 | 41                  | 95               | 3.9                 | 0.46     | 0.26     |
| 3000  | 3000  | none  | 32                  | 95               | 3.0                 | 0.35     | 0.20     |
| 2806  | 3900  | 10000 | 38                  | 108              | 4.2                 | 0.38     | 0.21     |
| 3900  | 3900  | none  | 28                  | 108              | 3.0                 | 0.27     | 0.15     |
| 2479  | 3900  | 6800  | 44                  | 108              | 4.7                 | 0.43     | 0.24     |
| 6800  | 6800  | none  | 21                  | 143              | 3.0                 | 0.16     | 0.09     |
| 4048  | 6800  | 10000 | 35                  | 143              | 5.1                 | 0.26     | 0.15     |
| 10000 | 10000 | none  | 14                  | 170              | 3.0                 | 0.11     | 0.06     |

| R     | Voltage Drop Against Current |     |     |     |     |     |    |    |     |     |     |     |     |     |     |    |
|-------|------------------------------|-----|-----|-----|-----|-----|----|----|-----|-----|-----|-----|-----|-----|-----|----|
|       | 9                            | 11  | 12  | 14  | 16  | 18  | 20 | 21 | 23  | 25  | 27  | 28  | 30  | 32  | 34  | 36 |
| 889   | 9                            | 11  | 12  | 14  | 16  | 18  | 20 | 21 | 23  | 25  | 27  | 28  | 30  | 32  | 34  | 36 |
| 1043  | 10                           | 13  | 15  | 17  | 19  | 21  | 23 | 25 | 27  | 29  | 31  | 33  | 35  | 38  | 40  | 42 |
| 1135  | 11                           | 14  | 16  | 18  | 20  | 23  | 25 | 27 | 29  | 32  | 34  | 36  | 39  | 41  | 43  | 45 |
| 1200  | 12                           | 14  | 17  | 19  | 22  | 24  | 26 | 29 | 31  | 34  | 36  | 38  | 41  | 43  | 46  | 48 |
| 1295  | 13                           | 16  | 18  | 21  | 23  | 26  | 28 | 31 | 34  | 36  | 39  | 41  | 44  | 47  | 49  | 52 |
| 1322  | 13                           | 16  | 19  | 21  | 24  | 26  | 29 | 32 | 34  | 37  | 40  | 42  | 45  | 48  | 50  | 53 |
| 1379  | 14                           | 17  | 19  | 22  | 25  | 28  | 30 | 33 | 36  | 39  | 41  | 44  | 47  | 50  | 52  | 55 |
| 1545  | 15                           | 19  | 22  | 25  | 28  | 31  | 34 | 37 | 40  | 43  | 46  | 49  | 53  | 56  | 59  | 62 |
| 1600  | 16                           | 19  | 22  | 26  | 29  | 32  | 35 | 38 | 42  | 45  | 48  | 51  | 54  | 58  | 61  | 64 |
| 1667  | 17                           | 20  | 23  | 27  | 30  | 33  | 37 | 40 | 43  | 47  | 50  | 53  | 57  | 60  | 63  | 67 |
| 1696  | 17                           | 20  | 24  | 27  | 31  | 34  | 37 | 41 | 44  | 47  | 51  | 54  | 58  | 61  | 64  | 68 |
| 2000  | 20                           | 24  | 28  | 32  | 36  | 40  | 44 | 48 | 52  | 56  | 60  | 64  | 68  | 72  | 76  | x  |
| 2082  | 21                           | 25  | 29  | 33  | 37  | 42  | 46 | 50 | 54  | 58  | 62  | 67  | 71  | 75  | 79  | 83 |
| 2308  | 23                           | 28  | 32  | 37  | 42  | 46  | 51 | 55 | 60  | 65  | 69  | 74  | 78  | 83  | 88  | 92 |
| 2479  | 25                           | 30  | 35  | 40  | 45  | 50  | 55 | 59 | 64  | 69  | 74  | 79  | 84  | 89  | 94  | 99 |
| 2806  | 28                           | 34  | 39  | 45  | 51  | 56  | 62 | 67 | 73  | 79  | 84  | 90  | 95  | 101 | 107 | x  |
| 3000  | 30                           | 36  | 42  | 48  | 54  | 60  | 66 | 72 | 78  | 84  | 90  | x   | x   | x   | x   | x  |
| 3900  | 39                           | 47  | 55  | 62  | 70  | 78  | 86 | 94 | 101 | x   | x   | x   | x   | x   | x   | x  |
| 4048  | 40                           | 49  | 57  | 65  | 73  | 81  | 89 | 97 | 105 | 113 | 121 | 130 | 138 | x   | x   | x  |
| 6800  | 68                           | 82  | 95  | 109 | 122 | 136 | x  | x  | x   | x   | x   | x   | x   | x   | x   | x  |
| 10000 | 100                          | 120 | 140 | x   | x   | x   | x  | x  | x   | x   | x   | x   | x   | x   | x   | x  |
| mA    | 10                           | 12  | 14  | 16  | 18  | 20  | 22 | 24 | 26  | 28  | 30  | 32  | 34  | 36  | 38  | 40 |

**GLASSWARE**  
**AUDIO DESIGN**

**[www.glass-ware.com](http://www.glass-ware.com)**

**[www.tubecad.com](http://www.tubecad.com)**

**[sales@glass-ware.com](mailto:sales@glass-ware.com)**

Copyright © 2009  
All Rights Reserved